

CARE AND OPERATION OF YOUR
THIMBLE-DROME
SPACE HOPPER
ENGINE



This engine is outstanding for sport flying, both control line and free flight.

Keep this engine immaculate clean, use Thimble Drome Glow Fuel in the blue can and it will maintain its winning characteristics for a long period of time.

This engine is precisely fitted at the factory for immediate, easy starting and immediate flight. A break-in period in the ordinary sense is not necessary for flight, in fact, a slow easy break-in is not desirable. Most of these engines will develop full power within one minute of running time; but a few, those which are slightly on the tight side, may not develop full power under one hour. Even these will develop sufficient power for average flying almost immediately. The only break-in required is very rich (slow) running the first 60 seconds after starting the first time. After 60 seconds it should be ready to go.

Elimination of break-in is not attained through loose or sloppy fitting but through very precise fitting, together with super fine wearing surfaces.

Remember—the Space Hopper is much happier at high speeds. Let it wind up. Do not use oversize props.

(A) PREPARATION FOR RUNNING

1. Mount the engine in the plane or, if you want to give it some running first, mount it on a suitable mount. Do not hold the engine directly in a vise. Use as a template, A-Fig. 1, to drill mounting holes for beam mounting. Use template, B-Fig. 1, to drill mounting holes for firewall mounting when using Thimble Drome nylon motor mounts. The screened nut, C-Fig. 1, in the rear is the air intake hole and must be left open.
2. Place propeller on the shaft with the flat side of the blades toward engine and lock securely with the propeller screw.
3. Use a Thimble-Drome filler spout with stainless steel strainer in your fuel can. Your engine will thus be filled direct from the can and protected from dirt and foreign matter that would otherwise stop up the carburetor jet. The strainer keeps dirt out of the can and any particles that might already be in the can, from getting into the carburetor jet.
4. Procure a 1 ½ volt dry cell battery, #6 or equivalent, and connect it with 2 flexible insulated wires to a glow plug clip as shown in the diagram A and B-Fig. 2. Do not use a stronger battery. If you do, the plug will burn out. The connections should be soldered to ensure good contact and taped to prevent bare ends of wire from getting together and "shortening" the battery. Be sure the battery is a good one. Your dealer sells batteries and glow plug clips. The Thimble-Drome plastic mounted glow plug clip with wires already attached is recommended.
5. Balance and trim propeller. This is very essential for good performance. Sand off any bead of plastic along edges of blades. Fit a drill or shaft through the hole and rest the shaft on razor blades set in wooden blocks as shown in C-Fig. 2. Sand the heavy blade until the propeller will balance in a horizontal position. Care must be exercised to do the sanding without spoiling the airfoil characteristics.

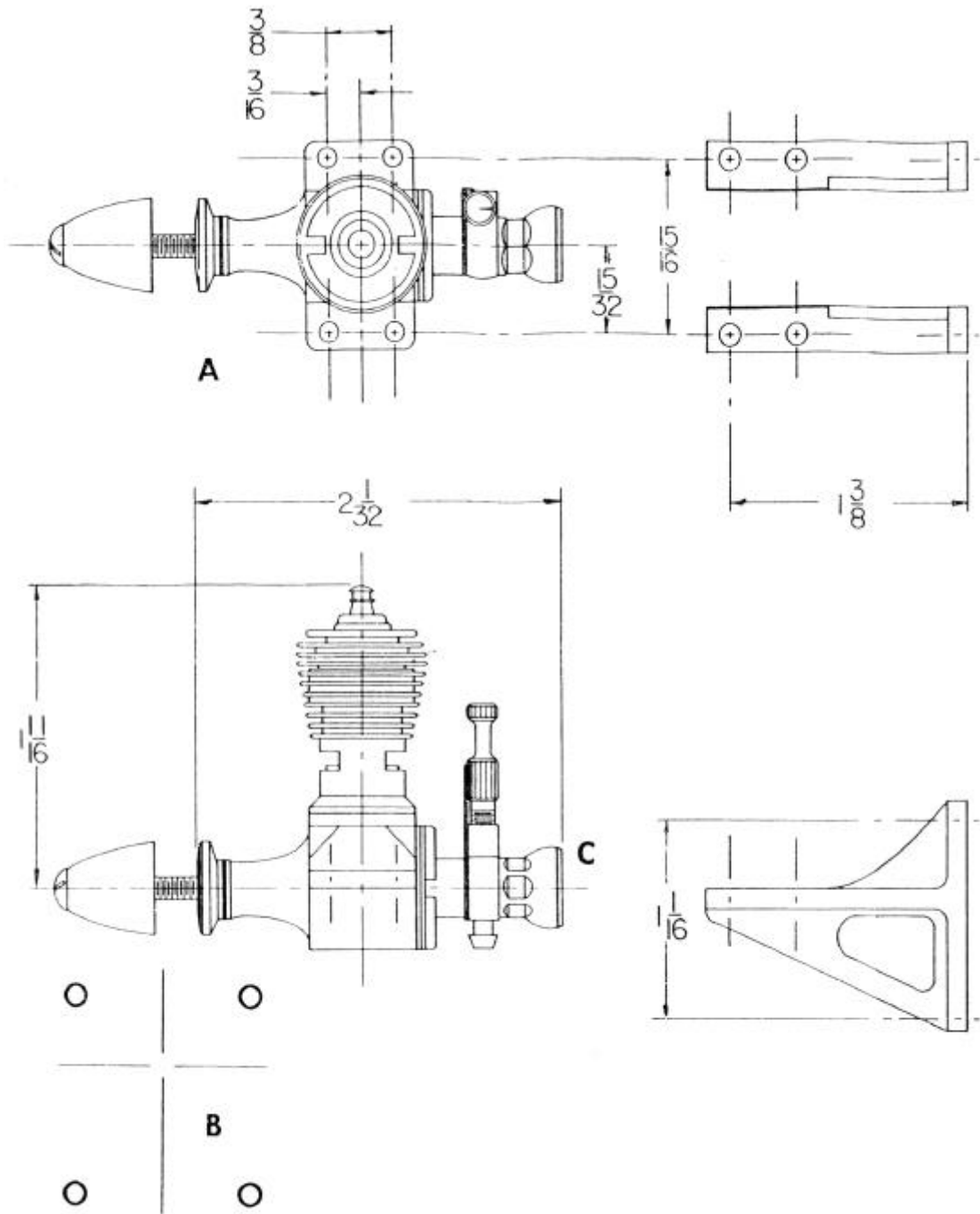

Fig. 1

**FULL SCALE VIEWS OF THE
 SPACE HOPPER FOR INSTALLATION INFORMATION**

(B) STARTING THE SPACE HOPPER

No matter how expert you are with small engines you will have better luck with this one if you follow directions exactly as listed and do each operation in the exact order given.

1. Close the carburetor needle valve, C-Fig. 1, by turning it clockwise till it stops. Do not force it.
2. Fill the fuel tank with Thimble-Drome racing fuel (in the red can).
3. Open the needle valve (counter clockwise) exactly $5\frac{1}{2}$ full turns.
4. If the fuel level in the tank is lower than the carburetor venturi, put your finger over the air intake at the rear of the engine and pull the prop thru compression twice. No more, no less. If the fuel level is equal in height to the venturi or slightly higher do not do this operation.
5. Connect the battery by snapping the clip on the glow plug. B-Fig. 2.
6. Engage the spring starter and pull the prop around one turn only. Stop so that the exhaust ports are open.
7. Squirt a few drops of fuel into the exhaust port and immediately release the prop. Release it by sliding your finger off the end of the blade and away so your finger is instantly out of range of the spinning propeller as the engine will start instantly when released if primed with the right amount of fuel.
8. When the engine starts it will be running very rich and slow. The first time the engine is started let it continue to run rich for a period of 60 seconds. After approximately 60 seconds, slowly close the needle valve clockwise to the best running position and remove the battery connection. Subsequent starts may be adjusted to best running position immediately.
9. If starting is delayed for any reason, close the needle valve otherwise the engine will become flooded.

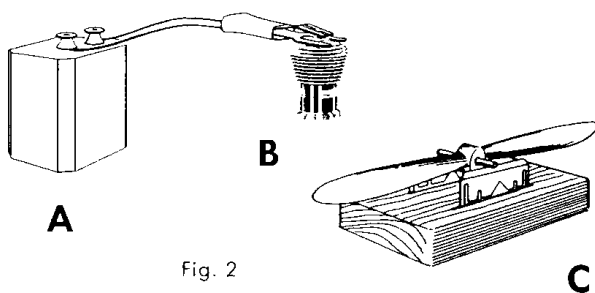

Fig. 2

(C) FAILURE TO START

1. If the engine coughs and spits a bit of fuel spray from the exhaust, it is too rich. Close the needle valve and continue cranking until the engine starts briefly. Open the needle valve again and crank it over. It should start immediately.
2. If it starts up with lots of power and dies immediately it is too lean. Open the needle valve a half turn, prime the engine, and crank it over again. If the trouble persists and the tank is lower than the carburetor try choking again as in Section B Par. 4. If the engine hasn't been run for some time it is also possible that thick castor oil is clogging the jets. Choking will clear this also.
3. If the engine still persists in above action it is possible the carburetor jets are stopped up. Remove the venturi nut and needle valve body. Three tiny jet holes will be found in the groove around the venturi tube. Clean these jet holes with a piece of fine wire. Reassemble and the engine should run.
4. If the engine refuses to fire at all screw the glow plug out and connect it to the clip. If the little coil inside does not get red hot, it is either burnt out or the battery is dead, or the connections are made incorrectly. Replace the battery or the plug, or, correct the connections. Glow plugs are never guaranteed. Do not return the engine to the factory for a burnt out glow plug because the cost to you will be excessive. Buy one from your dealer.
5. If you are not using Thimble-Drome fuel, try it. **Never use gasoline or gasoline type fuels.**
6. Very heavy priming is often required for starting. These engines do not flood out as easily as most. Unless it is actually spitting out raw fuel it may need even more priming even though you have already primed it as much as most engines will stand.
7. If the plug, battery, and connections are known to be good, and if the jet has been checked for stoppage, and if the fuel is known to be the correct kind, yet the engine will not fire at all, it is possible there is dirt or a piece of foreign matter under the reed valve. This is very unlikely unless the venturi screen has been removed. If the venturi screen has been removed you may expect this trouble. The foreign matter can sometimes be removed without taking the valve assembly apart. If it is necessary to take it apart, be sure to replace the reed with the same side against the venturi.

(D) OPERATING TIPS AND ENGINE CARE

1. The Glow plug is built right into the head in one unit. When the plug burns out just replace the entire head at the regular glow plug price.
2. After the last run, oil the engine with a light oil (SAE 10 is good) and wrap it with cloth or other-

wise protect it from dust and dirt.

3. If the engine gets dirt on it through crack-up, or otherwise, do not run it until it is thoroughly cleaned. Take it apart, wash it, oil it, and re-assemble.
4. If the engine gets tight it is not frozen up. Do not send to factory. A new engine will sometimes tighten up a few times, especially after slow runs. This is more likely to happen and will occur more often to an engine that is properly fitted and has properly smooth wearing surfaces. Do not run it tight. This is caused from a shellac like deposit on the cylinder wall. Screw the head off. **Remove the cylinder** and scour the inside wall very lightly with a bit of fine or medium steel wool. Wash, oil, and replace. The engine will then turn over freely and run good. **Never** use sandpaper, emery cloth, or abrasives of any kind, or scrapers. Such methods will ruin the cylinder. Steel wool will not harm the bore.
5. Certain kinds of weather, especially warm humid (sticky) weather will cause excessive shellacing in a new cylinder. There is no known way to eliminate this nuisance and the smoother the fit the more susceptible is the engine to this trouble.
6. Do not tighten the head too firmly. Set it up very lightly. Allow the engine to cool before removing head so it will loosen easier. To much pressure against the exhaust ports o hold the cylinder from turning may force the cylinder out of round or even turn a burr into the bore. A new cylinder is usually required to remedy such a damage.
7. To remove the glow plug from a hot engine—pour a little fuel slowly over the glow plug to reduce the plug temperature. Do not run it over the cylinder. The plug will then release easily. A hot plug will stick and forced removal may damage the cylinder.
8. Tampering with the reed valve can do no good unless it is necessary to remove dirt as per Sec. C Par. 7. The slightest bend or dent in the red may prevent the engine from running at all.
9. If the reed is ever replaced, be sure to put in the reed made for this engine.

SPECIFICATIONS

Wt.—1.3 oz. Bore—.406". Stroke—.386". Displacement .0499 cu. in. Overall height 2". Height above rails $1\frac{11}{16}$ ". Overall length $2\frac{21}{4}$ ". Width $1\frac{1}{8}$ ". Width rails $1\frac{21}{4}$ ". Overall length $2\frac{15}{16}$ ". Width $1\frac{1}{8}$ ". Width between centers of rail holes $\frac{15}{16}$ ". Piston, ground surface, no rings. Intake valve—reed. Rotation—right or left.

RPM—subject to fuel and weather conditions. The following readings taken from Electronic Stroboscope manufactured by Communications Measurements Laboratory: Engine—picked at random—1 hour running time—Fuel, Thimble-Drome. Weather—Cloudy, overcast. Temperature—68, Humidity—58. Barometric Pressure 1012.5 Milibars, Dew point—61, Elevation 200 ft. above sea level. Test—Static, Propellers—Tornado Plasticote, trimmed and balanced.

Propeller Size	Pitch	RPM
6"	3	over 17,500
6"	2	over 21,200
5"	3	over 21,000

Static Thrus using a 6"-3 Pitch propeller—17¼ ounces.

WARRANTY

This engine is guaranteed against defects in materials and workmanship for 30 days from date of purchase. Glow plugs are never guaranteed because of their delicate nature. No other guarantee is made or implied. If the engine is returned to factory within warranty, include 50c to cover cost of handling and return postage.

Do not take engine back to your dealer.

FACTORY REPAIR SERVICE

Minor repairs, examinations, or adjustments—\$1.00 plus parts. Complete overhaul (guaranteed new engine performance)—\$3.75, including parts. On all C.O.D. shipments, purchaser pays postage and C.O.D. fees.

PARTS ORDERS

Purchase parts from your dealer. If not available, order direct from factory. No C.O.D.'s please. Send remittance with your order. On orders less than \$2.00 add 35c handling charge. In California add 4% sales tax.

Prices and design of parts subject to change without notice.

ENGINE PARTS LIST FOR THE SPACE HOPPER ENGINE

Catalogue Number	Part	List Price
1501	Crankcase.....	1.50
302-1	Glow Head65
303	Piston and Rod	1.50
304-1	Cylinder	1.50
365	Crankshaft	1.50
363	Reed Retainer15
364	Reed Valve25
1509	Needle Valve and Spring60
352	Prop Drive Plate.....	.15
1516	Venturi Nut with Screen.....	.20
379	Prop Spinner and Screw.....	.25
1530	Wrench25
1524	Carburetor Body.....	1.50
1525	Carburetor Complete	2.50
1526	Needle Valve Body.....	.60
1560	Motor Mounts—Pair.....	.50

Order Parts by Catalogue Number

L. M. COX MANUFACTURING CO.

730 Poinsettia P.O. Box 476 Santa Ana, Calif.

Litho by Cox Mfg. — U.S.A. 4-59 1 5 59