

Care and Operation of your THIMBLE-DROME Space-Bug Jr. ENGINE

Keep this engine immaculately clean, use **Thimble Drome Glow Fuel** and it will maintain its easy starting and fine characteristics.

This engine is precisely fitted at the factory for **immediate, easy starting** and immediate flight. A break-in period in the ordinary sense is not necessary. In fact, a slow, easy break-in is not desirable. Most of these engines will develop full power within one minute of running time. Do not run is slow for the first few runs. Lean it out and let it wind up, the faster the better. The first run may be rough and slightly erratic for about one minute.

Elimination of break-in is not attained through loose or sloppy fitting but through very precise fitting, together with super fine wearing surfaces.

(A) PREPARATION FOR RUNNING

1. Mount the engine in the plane or, if you want to give it some running first, mount it on a narrow board, about 2" wide and fasten the other end of the board in a vise or nail it to something. **Do not hold the engine directly in a vise.** The 4 ears at the rear of the tank are for mounting. Use the template, A, Fig. 1, to drill mounting holes and breather hole. **The screened opening, B, Fig. 1, in the rear is the air intake hole and must be left open.**
2. Place propeller on the shaft with the flat side of the blades toward the engine. **Do not over tighten the propeller nut or you will break the crankshaft in the threads. Just snug it up. Crankshaft breakage is not guaranteed,** as it is invariably caused by stresses of overtightening nut which is entirely unnecessary. Easy crankshaft breakage in crackups is caused by impact stresses added to the stresses of overtightening which add up to the breaking point.
3. Get a new or thoroughly cleaned oil can and slip a piece of $\frac{1}{8}$ " neoprene tubing on the spout. This will be used for filling the fuel tank. If you prefer you can buy a fuel pump from your dealer to screw directly on to the fuel can.

4. Procure a 1 ½ volt dry cell battery, #6 or equivalent, and connect it with 2 flexible insulated wires to a glow plug clip as shown in the diagram A & B, Fig. 2. Do not use a stronger battery. If you do the plug will burn out. The connections should be soldered to ensure good contact and taped to prevent bare ends of wire from getting together and "shortening" the battery. Be sure the battery is a good one. Your dealer sells batteries, wire, and glow plug clips.

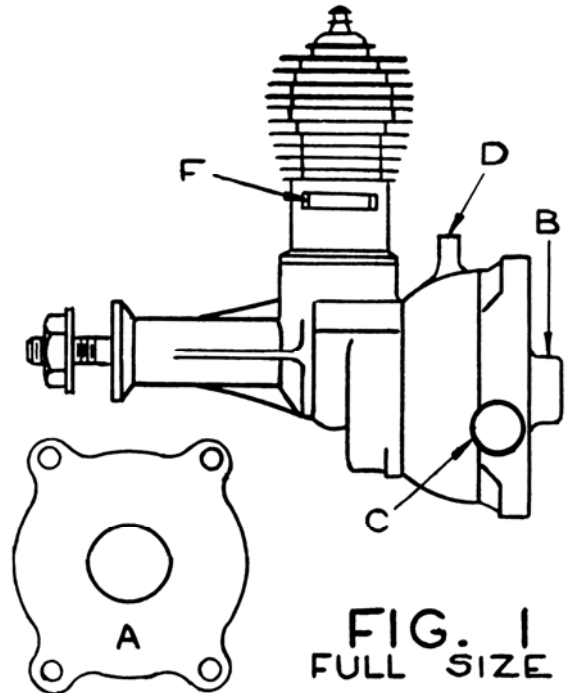

(B) STARTING THE SPACE-BUG JR. ENGINE

No matter how expert you are with small engines you will have better luck with this one if you follow directions exactly as listed and do each operation in the exact order given.

1. Close the carburetor needle valve, C, Fig. 1, by turning it clockwise till it stops. **Do not force it.**
2. Slip the filler hose of your pump or fuel can over the filler tube D, Fig. 1, pump in fuel until it overflows. Do not use gasoline. **Use Thimble-Drome Glow Fuel in the blue can.** Do not use Nitro Benzene fuels with the shoe polish odor. They will ruin your engine.
3. Connect the battery by snapping the clip on the glow plug, B, Fig. 2.
4. Open the needle valve (counter clockwise) exactly 3 full turns.
5. Turn the propeller to the position so that the exhaust ports F, Fig. 1 are wide open. Squirt 5 or 6 drops of fuel into the cylinder through one of the port openings. This is called priming.

Replica Manual
Space-Bug Jr.
Thimble Drome

6. Flip the propeller over snappily with the finger tip to start. Use a Thimble-Drome Finguard to protect your fingers.
7. When the engine starts it will be running very rich and slow. Immediately start slowly closing the needle valve clockwise until the engine breaks into 2 cycle operation, then adjust it so that it runs smoothly. If it does not smooth out, let it run a little longer, then adjust it again.
8. When the engine is cold it will require almost a minute to warm up to perfect 2 cycle operation when leaned out. When starting a warm or hot engine this period will be reduced to a matter of only a few seconds. Best performance can only be had when the engine is hot.
9. Should the engine run backwards, stop it by putting finger over propeller nut and putting pressure on propeller or closing needle valve. As soon as it stops flip it again. It is likely to start in either direction. If it does, there is nothing wrong with it. The direction it starts is mostly chance. Harder flipping in the correct direction or very easy flipping in the reverse direction may help. Do not send it to the factory for repair if it starts backward as there is nothing we can do to correct this.

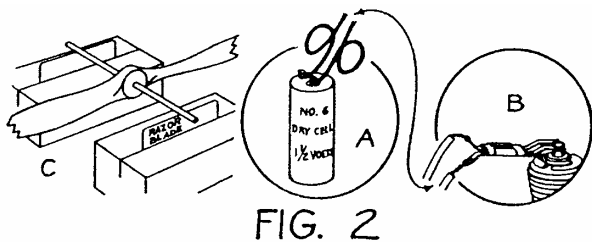

FIG. 2

(C) FAILURE TO START

1. If there is bubbling or leakage at the crank case gasket when the prop is turned, remove the engine and tighten the 4 screws in the rear of the tank about $\frac{1}{2}$ turn. Do not overtighten these screws as damage to the carburetor will result.
2. If the engine coughs and spits a bit of fuel spray from the exhaust, it is too rich. Close needle valve to 2 turns, crank without priming for a few seconds and it should start.
3. If it starts up with lots of power and dies immediately it is too lean. Open the needle valve a half turn, prime the engine, and crank it over again.
4. If the engine fires with a burst of power then dies repeatedly after each time it is primed, and this is not cured by opening the needle valve more, the fuel jet is stopped up. If the engine has not been run for some time it is likely that it is only stopped up with castor oil. Choke the engine by holding a finger over the intake, B, Fig. 1, and flip the propeller over 3 or 4

times. This will remove the castor oil and the engine should start. If the same symptoms re-occur, the jet possibly has dirt in it and this should be blown out as per next paragraph.

5. Stopped up fuel line or jet. Remove needle valve. Blow in to fuel filler tube, D, Fig. 1, with high pressure air such as available at service stations. Never blow in the venturi screened opening, B, Fig. 1.
6. If the engine acts like it is not getting enough fuel and blowing out the jet does no good the next step is to take the tank apart, wash both halves in clean gasoline, and blow out all holes in the rear half of tank with high pressure air; especially the fuel pick up hole.
7. If the engine refuses to fire at all screw the glow plug out and connect it to the clip. If the little coil inside does not get red hot, it is either burnt out or the battery is dead, or the connections are made incorrectly. Replace the battery or the plug, or, correct the connections. Glow plugs are never guaranteed. Do not return the engine to the factory for a burnt out glow plug because the cost to you will be excessive. Buy one from your dealer.
8. Weak cranking sometimes retards starting. Crank with a snap.
7. If you are not using Thimble-Drome Glow fuel, try it. Never use gasoline or gasoline type fuels.
8. Very heavy priming is often required for starting. These engines do not flood out as easily as most. Unless it is actually spitting out raw fuel it may need more priming even though you have already primed it as much as most engines will stand.
9. If the plug, battery, and connections are known to be good, and if the jet has been checked for stoppage, and if the fuel is known to be the correct kind, yet the engine will not fire at all, it is possible there is dirt or a piece of foreign matter under the reed valve. This is very unlikely unless the venturi screen has been removed. If the venturi screen has been removed you may expect this trouble. Refer to Operating Tips, Par. 8 to correct this trouble.

(D) OPERATING TIPS

1. **EXTREMELY IMPORTANT**—Do not tighten screws too much that hold tank and engine together. If screwed up too tight, valve seat will be pulled out of line, and engine will not run.
2. Be very careful to start needle valve straight to prevent cross threading. If it starts to turn hard, do not force it as it is starting crooked. Remove and start straight.
3. When using wrench on cylinder be sure it is all the way on. If it is not, the tip may slip through the port and put a burr on the cylinder which usually ruins it. Piston will then be tight. This damage is not guaranteed.

OPERATING TIPS (Cont.)

4. Never put a bar through the ports to hold or turn cylinder. Never take hold of cylinder with pliers. Use your wrench on cylinder and another wrench (or pliers) on cylinder head. Extra wrenches can be secured from your dealer or directly from factory.
5. Always empty the fuel tank on your last run by running the engine until it quits. Never put the engine away with fuel in it.
6. After the last run, oil the engine with a light oil (SAE 10 is good) and wrap it with cloth or otherwise protect it from dust and dirt.
7. If the engine gets dirt on it through crack-up, or otherwise, do not run it until it is thoroughly cleaned. **Take it apart**, wash it, oil it, and re-assemble.
8. Do not tamper with the reed valve assembly unless it is known that dirt is in the reeds. This is a very critical part of the engine and tampering can do no good. If foreign matter becomes lodged under the reeds it may be taken out by lifting the end of the reed and picking the part out with a fine piece of wire or splinter of wood, or washing out with fuel or gasoline. The reed is springy but caution must be exercised in lifting the end because if the reeds are bent too far they will take a permanent set and the engine will not run.
9. If the engine gets tight it is not frozen up. Do not send to factory. A new engine will sometimes tighten up a few times, especially after slow runs. This is more likely to happen and will occur more often to an engine that is properly fitted and has properly smooth wearing surfaces. Do not run it tight. This is caused from a shellac like deposit on the cylinder wall. Screw the head off. **Remove the cylinder** and scour the inside wall very lightly with a bit of fine or medium steel wool. Wash, oil, and replace. The engine will then turn over freely and run good. **Never** use sandpaper, emery cloth, abrasives of any kind, or scrapers. Such methods will ruin the cylinder.
10. Erratic running may be caused by an unbalanced propeller, or by a tight piston fit caused by shellacking of the cylinder. Refer to Par. 9 and 15 this section.
11. Propellers from 5"-6" long and 2½ to 4 pitch will give maximum performance and smooth running, depending on application.
12. Do not tighten the head too firmly. Set it up very lightly. Allow the engine to cool before removing head so it will loosen easier. Too much pressure against the exhaust ports to hold the cylinder from turning may force the cylinder out of round or even turn a burr into the bore. A new cylinder is usually required to remedy such damage.
13. Always use a well balanced propeller. To check balance, mount propeller on razor blades as shown in Fig. 2. Sandpaper the heavy blade without spoiling the airfoil section.
14. Space Bug or Thermal Hopper carburetor will not function properly on this engine. For extra power it is better to buy the other engine.
15. The Space Bug aluminum propeller nut (Cat. # 317, list price 20c) makes it easier to stop the engine when it starts backward and it also enhances the beauty of your engine.
16. **If the plane requires the engine to be mounted with the cylinder pointed down or pointed to the right or left, do not turn the tank over. Remove the 4 screws which hold the tank and crankcase together. Pull the crankcase off the nose of the tank, turn it to the desired position and replace the screws. Do not rotate back half of tank to a different position or carburetor will not pick up fuel.**
17. The first time you start your engine the excess castor oil from the exhaust will be dark colored for a few seconds but will clear up immediately. All engines do this if they have never been run before. This is due to the excessive wear during the first few seconds as the wearing surfaces polish in.
18. This engine will run at full power in either direction and may be used on a pusher plane using a standard propeller.

SPECIFICATIONS

Wt.—1 1/3 oz. Bore—.406", Stroke .386", Displacement .0499 cu. in. Mounting—radial, Overall height—2 1/16", Length—2 5/8", Width—1 1/8", Shaft size—1/8", Piston—no rings, Intake Valve—reed, Rotation—right or left. Horse power .054.

R.P.M., using Thimble-Drome Glow Fuel, and 5½"-2½ pitch propeller—15,000 to 16,000, according to weather.

WARRANTY

This engine is guaranteed against defects in materials and workmanship for 30 days from date of purchase. Glow plugs are never guaranteed because of their delicate nature. No other guarantee is made or implied. If the engine is returned to the factory within warranty, include 50c to cover cost of handling and return postage. **Do not take engine back to your dealer. No engine will be returned unless 50c is included.**

FACTORY REPAIR SERVICE

Minor repairs, examinations, or adjustments—\$1.00 plus parts. Complete overhaul (guaranteed new engine performance—\$2.50, including parts. On all COD shipments, purchaser pays postage and COD fees.

DAMAGE NOT GUARANTEED

Burrs at ports caused by wrench. (Sec D, Par. 3)
 Crankshaft breakage. (Sec. A, Par. 3)
 Conrod pulled loose from forcing a tight engine.
 Tight piston. (Sec. D, Par. 9)
 Fuel shutoff as described, Sec. D, Par. 16.
 Glow plug failure. (Sec. C, Par. 6.)
 Failure or tightness due to cheap fuels, or nitro benzene fuel. (Sec. B, Par. 2.)
 Crash damage or operator inflicted damage.

PARTS ORDERS

Purchase parts from your dealer. If not available, order direct from factory. No COD's please. Send remittance with your order. On orders less than \$2.00 add 35c handling charge. In California add 3% sales tax.

Prices and design of parts subject to change without notice.

ENGINE PARTS LIST For .049 Space-Bug Jr.

Catalogue Number	Part	List Price
301-J	Crankcase	\$1.25
302	Glow Head65
303-J	Piston & Rod	1.50
304-J	Cylinder	1.50
305	Crankshaft	1.75
309	Needle Valve & Spring60
310	Propeller Drive Washer.....	.15
312-J	Fuel Tank With Reed valve Assembly	1.50
314-J	Gasket10
315-J	Set of Screws.....	.15
317-J	Propeller Nut & Washer10
318-J	Propeller—5½"-2½" pitch20
319	Space Bug Decal Set.....	.20
320	Wrench.....	.25

ACCESSORIES

317	Propeller Nut—(aluminum)20
325	Fingeguard25

When Ordering Engine Parts, Use Catalogue Number

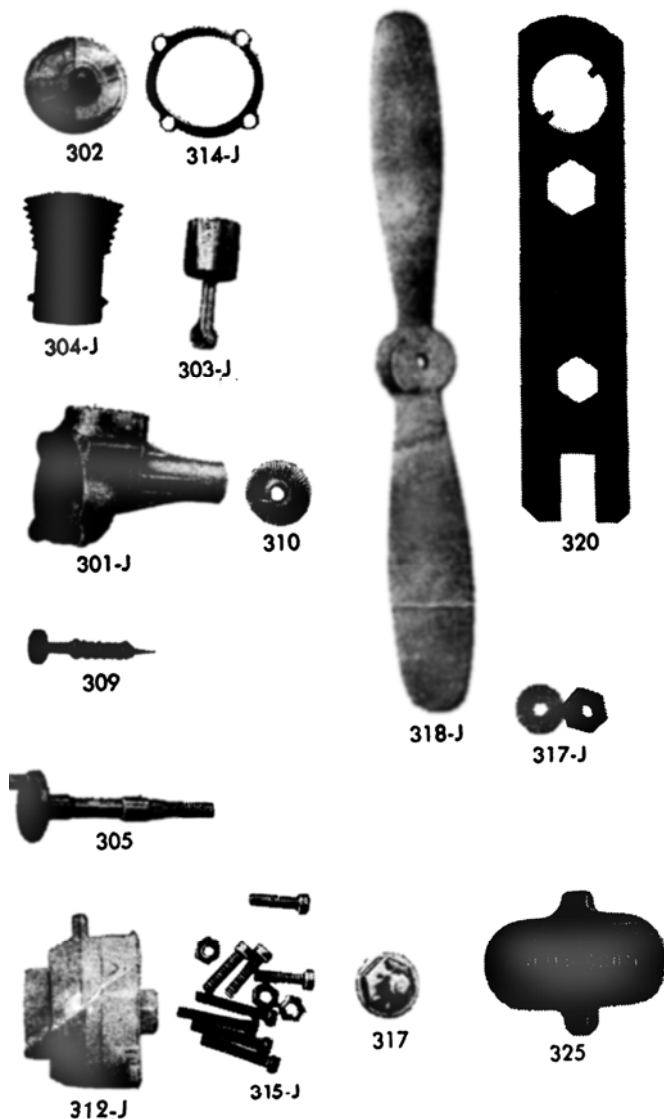

L. M. COX MANUFACTURING CO., INC.
 730 Poinsettia, P. O. Box 476, Santa Ana, Calif.