

CARE AND OPERATION OF YOUR Thimble-Drome "THERMAL-HOPPER" ENGINE

The fastest and most powerful
engine in the 1/2 A Class.
VERY easy starting.

No other manufacturer of 1/2A engines
can truthfully make this claim.

Keep this engine immaculately clean, use **Thimble Drome Racing Fuel**, and it will maintain its winning characteristics for a long period of time.

This engine is precisely fitted at the factory for **immediate, easy** starting and immediate flight. A break-in period in the ordinary sense is not necessary for flight, in fact, a slow easy break-in is not desirable. Most of these engines will develop full power within one minute of running time; but a few, those which are slightly on the tight side, may not develop full power under one hour. Even these will develop sufficient power for average flying almost immediately. The only break-in required is very rich (slow) running the first 60 seconds after starting the first time. After 60 seconds it should be ready to go.

Elimination of break-in is not attained through loose or sloppy fitting but through very precise fitting, together with super fine wearing surfaces.

(A) PREPARATION FOR RUNNING

1. Screw needle valve in **very carefully**. The threads are fine and starting cross threaded will necessitate new parts. These parts have been screwed to-gether at the factory and are known to fit properly.
2. Mount the engine in the plane or, if you want to give it some running first, mount it on a narrow board, , about 2" wide and fasten the other end of the board in a vise or nail it to something. **Do not hold the engine directly in a vise.** Use as a template, A-Fig. 1, to drill mounting holes and carburetor hole. **The screened nut, B-Fig. 1, in the rear is the air intake hole and must be left open.**
3. Place propeller on the shaft with the flat side of the blades toward the engine and lock securely with the propeller nut.
4. Mount the fuel tank as closely as possible and for quicker starting mount it so the fuel level when full is lightly higher than the carburetor venturi. Connect the tank to the

carburetor by slipping the fuel line over the fuel line fitting. C Fig. 1.

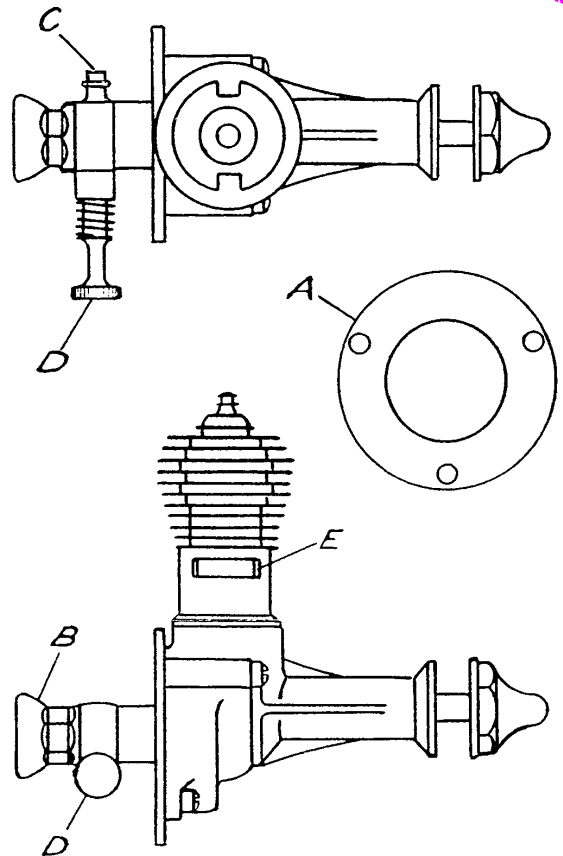

FIG. 1 FULL SIZE

5. Procure a 1 1/2 volt dry cell battery, #6 or equivalent, and connect it with 2 flexible insulated wires to a glow plug clip as shown in the diagram A & B-Fig. 2. Do not use a stronger battery. If you do the plug will burn out. The connections should be soldered to ensure good contact and taped to prevent bare ends of wire from getting together and "shortening" the battery. Be sure the battery is a good one. Your dealer sells batteries, wire, and glow plug clips.
6. Balance and trim propeller. This is very essential for good performance. Sand off any bead of plastic along edges of blades. Fit a drill or shaft through the hole and rest the shaft on razor blades set in wooden blocks as shown in C-Fig. 2. Sand the heavy blade until the propeller will balance in a horizontal position. Care must be exercised to do the sanding without spoiling the airfoil characteristics.

(B) STARTING THE THERMAL-HOPPER ENGINE

No matter how expert you are with small engines you will have better luck with this one if you follow directions exactly as listed and do each operation in the exact order given.

1. Close the carburetor needle valve, D-Fig. 1, by turning it clockwise till it stops. Do not force it.
2. Fill the fuel tank. Do not use gasoline. Use Thimble-Drome Glow Fuel or, better yet, use Thimble-Drome Racing Fuel.
3. Connect the battery by snapping the clip on the glow plug. B-Fig. 2.

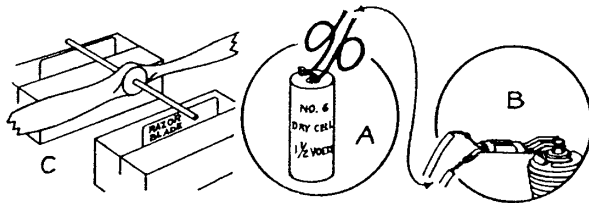

FIG. 2

4. Open the needle valve (counter clockwise) exactly $4 \frac{1}{2}$ full turns.
5. Turn the propeller to the position so that the ex-haust ports E-Fig. 1 are wide open. Squirt 5 or 6 drops of fuel into the cylinder through one of the port openings. This is called priming.
6. Flip the propeller over snappily with the finger tip to start. Use a Thimble-Drome Fingerguard to protect your fingers.
7. When the engine starts it will be running very rich and slow. The first time the engine is started let it continue to run rich for a period of 60 sec-onds, the slower the better. After approximately 60 seconds, slowly close the needle valve clockwise to the best running position and remove the battery connection. Subsequent starts may be adjusted to best running position immediately.
9. Should the engine run backwards, stop it by putting finger over propeller nut and putting pressure on propeller. As soon as it stops flip it again. It is likely to start in either direction. If the engine starts several times backwards, there is nothing wrong with it. The direction it starts is mostly chance. Lower compression will help it start the way it is cranked but it will run slower. Harder flipping in the correct direction or very easy flip-ping in the reverse direction may help.

(C) FAILURE TO START

1. If the engine coughs and spits a bit of fuel spray from the exhaust, it is too rich. Close the needle valve and continue cranking until the engine starts briefly. Open the needle valve again and crank it over. It should start immediately.
2. If it starts up with lots of power and dies immediately it is too lean. Open the needle valve a half turn, prime the engine, and crank it over again.
3. If the engine fires with a burst of power then dies repeatedly after each time it is primed, and this is not cured by opening the needle valve more, the fuel jet is stopped up. If the engine has not been run for some time it is likely that it is only stopped up with castor oil. Choke the engine by holding a finger over the intake, B-Fig. 1, and

flip the propeller over 3 or 4 times. This will remove the castor oil and the engine should start. If the same symptoms re-occur, the jet possibly has dirt in it and this should be cleaned out as per next paragraph.

4. Stopped up fuel line or jet. Remove hose. Open needle valve or remove it and blow into fuel hose connector with high pressure air. It may be necessary to remove the venturi screened nut, then remove the needle valve assembly and clean the jet holes in the venturi with fine wire. Never blow in to venturi.
5. If the engine refuses to fire at all screw the glow plug out and connect it to the clip. If the little coil inside does not get red hot, it is either burnt out or the battery is dead, or the connections are made incorrectly. Replace the battery or the plug, or, correct the connections. Glow plugs are **never** guaranteed. Do not return the engine to the factory for a burnt out glow plug because the cost to you will be excessive. Buy one from your dealer.
6. Weak cranking sometimes retards starting. Crank with a snap.
7. If you are not using Thimble-Drome fuel, try it. **Never use gasoline or gasoline type fuels.**
8. Very heavy priming is often required for starting. These engines do not flood out as easily as most. Unless it is actually spitting out raw fuel it may need even more priming even though you have already primed it as much as most engines will stand.
9. If the plug, battery, and connections are known to be good, and if the jet has been checked for stoppage, and if the fuel is known to be the correct kind, yet the engine will not fire at all, it is possible there is dirt or a piece of foreign matter under the reed valve. This is very unlikely unless the venturi screen has been removed. If the venturi screen has been removed you may expect this trouble. The foreign matter can sometimes be removed without taking the valve assembly apart. If it is necessary to take it apart, pry the reed housing off with 2 screw drivers, using them on opposite sides of the cap simultaneously. Refer to Section D, Par. 4.

(D) OPERATING TIPS AND ENGINE CARE

1. Connecting rod trouble will result from running an engine that is tight. Tightening should be remedied as soon as it is noticed. Refer to Par. 5.
2. After the last run, oil the engine with a light oil (SAE 10 is good) and wrap it with cloth or otherwise protect it from dust and dirt.

OPERATING TIPS (D)—Continued

3. If the engine gets dirt on it through crack-up, or otherwise, do not run it until it is thoroughly clean- ed. **Take it apart**, wash it, oil it, and re-assemble.
4. Do not tamper with the reed valve assembly unless it is known that dirt is inside the reeds. This is a very critical part of the engine and tampering can do no good. If it is necessary to remove the reeds, pry off the housing to get them out. All valve parts must be handled with extreme care and must be replaced in the exact position and in the exact order they were in before removal. To re-assemble, place the housing on a smooth hard surface. Put the valve components in place. Put the backplate

against the housing and with a piece of wood over the venturi tube for a cushion, drive it lightly in to place.

5. If the engine gets tight it is not frozen up. Do not send to factory. A new engine will sometimes tighten up a few times, especially after slow runs. This is more likely to happen and will occur more often to an engine that is properly fitted and has properly smooth wearing surfaces. Do not run it tight. This is caused from a shellac like deposit on the cylinder wall. Screw the head off. **Remove the cylinder** and scour the inside wall very lightly with a bit of fine or medium steel wool. Wash, oil, and replace. The engine will then turn over freely and run good. **Never** use sandpaper, emery cloth, or abrasives of any kind, or scrapers. Such methods will ruin the cylinder.
6. Erratic operation or rapid drop from peak power soon after starting may be caused by any one or more of the following: Propeller out of balance, setting up undue vibration—re-balance or replace propeller. 2, shellacing of the cylinder, causing tight fit. This occurs only on fairly new engines—refer to Par. 5 for remedy. 3, loose needle valve—replace with a new one or stretch the spring slightly to increase pressure on needle. 4, Incorrect head compression—usually low—remove a head gasket. If this does not smooth out operation noticeably replace the gasket. 5, Improper fuel mixture—try Thimble-Drome Racing Fuel.
7. Due to the very precise nature of the fitting of various parts a break-in period is not necessary. The engine is ready to start and ready to fly. With proper care, especially concerning clean operating conditions and protection from dust and dirt, as well as use of properly lubricated fuels, the engine will continue to improve in power and speed for many running hours.
8. During the first 2 hours of running time do not use a propeller that will lug the engine. A 6"-3 pitch, a 6"-2 pitch, or a 5"-4 pitch will do. Unless you are flying a very small or very fast plane do not use more pitch than recommended because lugging the engine will cause the cylinder to shellac up and get tight.
9. Certain kinds of weather, especially warm humid (sticky) weather will cause excessive shellacing in a new cylinder. There is no known way to eliminate this nuisance and the smoother the fit the more susceptible is the engine to this trouble.
10. Do not tighten the head too firmly. Set it up very lightly. Allow the engine to cool before removing head so it will loosen easier. To much pressure against the exhaust ports o hold the cylinder from turning may force the cylinder

out of round or even turn a burr into the bore. A new cylinder is usually required to remedy such a damage.

11. Do not under any circumstances use a plastic propeller on this engine unless the manufacturer of such propeller expressly recommends it for use on Thimble-Drome engines and so labels it. The speeds attained by this engine will throw the blades off such propellers within a short while. This is highly dangerous as the blades fly like bullets.
12. This engine is equipped with a Standard Head # 302. The racing head, # 302RH, available from your dealer, will under certain weather conditions only, increase rpm as high as 700 rpm. Under other conditions rpm may be reduced.
13. Compression ratio determined by head and gaskets have much to do with the speed of an engine, starting, and smooth running. Always empty the fuel tank on your last run by running the engine until it quits. Never put the engine away with fuel in it.
14. The first time you start your engine the excess castor oil from the exhaust will be dark colored for a few seconds but will clear up immediately. All engines do this if they have never been run before. This is due to the excessive wear during the first few seconds as the wearing surfaces polish in.
15. Do not under any circumstances, run this engine with a flywheel only. The terrific speeds with resulting heat would ruin the engine in a matter of seconds.
16. This engine will run at full power in either direction and may be used on a pusher plane using a standard propeller.

SPECIFICATIONS

Weight, 1.35 oz. Bore—.406", Stroke .386", Displacement .0499 Cu. In. Mounting radial, Overall Height, 2³/₈", Overall Length, 2 3/16", Width, 1¹/₈", Shaft Size, 1/8", Piston—no rings, Intake Valve—reed, Rotation—right or left.
 RPM—subject to fuel and weather conditions. The following readings taken from Electronic Stroboscope manufactured by Communications Measurements Laboratory: Engine—picked at random—1 hour running time—Fuel, Thimble Drome. Weather—Cloudy, overcast. Temperature—68, Humidity—58, Barometric Pressure 1012.5 Milibars, Dew Point—61, Elevation 200 ft. above sea level. Test—Static, Propellers—Tornado Plasticote, trimmed and balanced.

Engine	Propeller Size	Pitch	RPM
Thermal Hopper	6"	3	over 17,000
" "	6"	2	over 20,200
" "	5"	3	over 21,000

Static Thrust using a 6"-3 Pitch Propeller—17 1/4 ounces.

WARRANTY

This engine is guaranteed against defects in materials and workmanship for 30 days from date of purchase. Your warranty card must be in our file, signed and dated by your dealer. Glow plugs are never guaranteed because of their delicate nature. No other guarantee is made or implied. If the engine is returned to the factory within warranty, include 50c to cover cost of handling and return postage. **Do not take engine back to your dealer.**

FACTORY REPAIR SERVICE

Minor repairs, examinations, or adjustments—\$1.00 plus parts. Complete overhaul (guaranteed new engine performance—\$3.75, including parts. On all C.O.D. shipments, purchaser pays postage and C.O.D. fees.

PARTS ORDERS

Purchase parts from your dealer. If not available, order direct from factory. No C.O.D.'s please. Send remittance with your order. On orders less than \$2.00 add 35c handling charge. In California add 3% sales tax.

Prices and design of parts subject to change without notice.

ENGINE PARTS LIST For .049 Thermal-Hopper

Catalogue Number	Part	List Price
301	Crankcase	\$1.50
302	Cylinder Head & Glow Plug (standard)65
302 RH	Cylinder Head & Glow Plug (racing head)65
303	Piston and Rod	1.50
304	Cylinder	1.50
305	Crankshaft	1.75
306	Reed Housing	0.25
307	Reed Back Plate25
308	Set of Reeds50
309	Needle Valve & Spring60
310	Propeller Drive Washer15
314 TH	Gasket Set20
315 TH	Set of Screws15
316 TH	Venturi Nut & Filter Screen25
317	Propeller Nut20
318	Propeller 6"-3 Pitch25
319	Space Bug Decal Set20
320	Wrench25
323	Carburetor, Complete	3.00
324	Carburetor Body	1.50
326	Needle Valve Body60

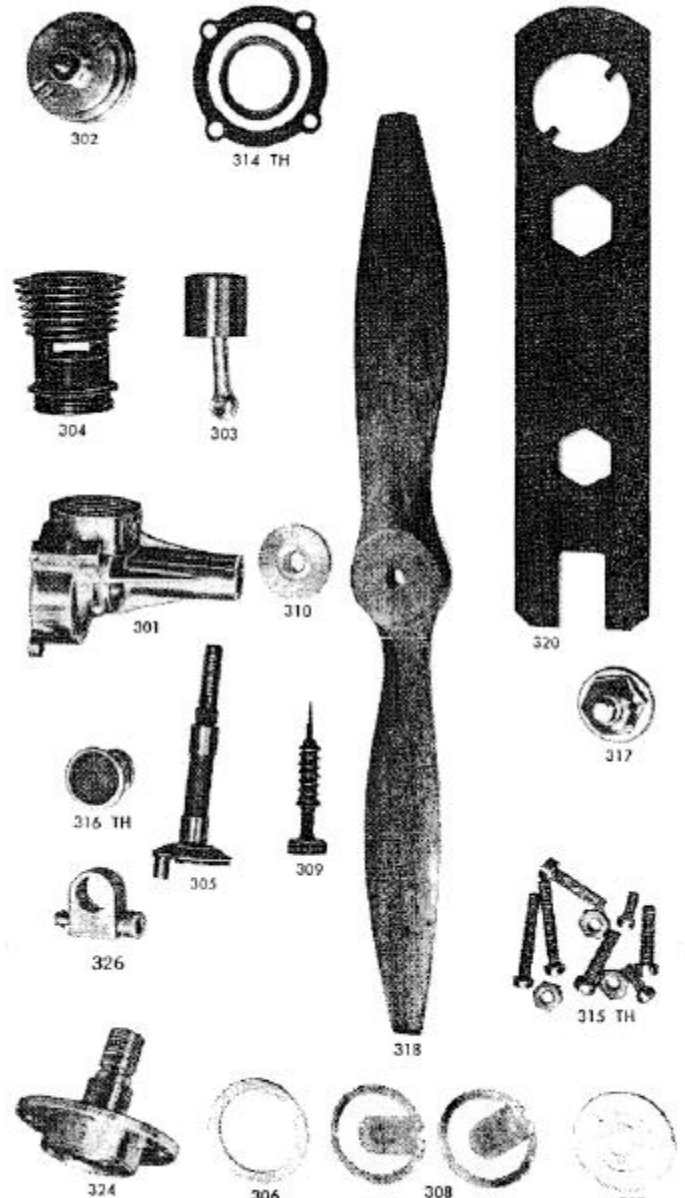

L. M. COX MANUFACTURING CO., INC.
730 Poinsettia, P. O. Box 476, Santa Ana, Calif.

**When Ordering Engine Parts,
Use Catalogue Number**